

IMPORTANT: APOLLO STRONGLY RECOMMENDS SENDING YOUR COMPUTER TO: MIDWEST SCUBA CENTER PHONE: (317) 272-4000 THIS IS THE ONLY AUTHORIZED FACILITY FOR BATTERY CHANGE. BATTERY CHANGE ON THIS UNIT IS DIFFICULT AND IRREPARABLE DAMAGE CAN OCCUR IF PERFORMED IMPROPERLY.

PLEASE NOTE: CHANGING THE BATTERY ON THE PICO COMPUTER GAUGE WILL CLEAR ALL LOGGED DIVE MEMORY FROM THE UNIT. PLEASE WRITE DOWN ALL INFORMATION YOU WANT TO KEEP PRIOR TO REMOVING THE BATTERY.

USE OF THE IMPROPER TOOLS WILL RESULT IN DAMAGE TO THE UNIT.

PAGE 1-2 DIRECTIONS • PAGE 3-6 ILLUSTRATIONS

Remove the 5 screws on the back of the gauge (fig 1, item 1).

Remove the stainless steel back cover and gasket (fig 2, item 1).

Special tools are required to remove the wrist strap retainer and back cover.

- Wrist strap retainer and battery holding plate require: "00" Phillips head screw driver
- Torx driver size "T-6" is required to remove back cover.

NOTE: Back cover should be placed face up (printed side up [fig 3] to protect sealing surface) while replacing the battery. Check the sealing surface of the back cover to ensure there are no scratches or small dirt particles which could cause leakage after re-assembly.

On wrist units: remove the 4 screws holding the wrist strap retainer and remove. Hold down on the battery holding plate marked "  " in (fig 2, item 3) with one finger (*this plate is spring loaded and requires pressure to hold it in place during disassembly*) unscrew screw (fig 2, item 4). Slowly remove finger from the small plate being careful not to allow the plate to spring out.

Remove battery holding plate and screw together by lifting straight up.

Remove battery using tweezers or a small screw driver, carefully "pry up" the battery and remove (fig 7/8).

Replacing the battery: Place the battery (#CR3032) in the battery frame. Insert one end of the battery holding plate into the hole on the circuit board, be certain to insert the end without hole. Press lightly on the battery holding plate marked "  " (fig 2, item 3). Line up hole in plate and circuit board (fig 11). Replace the screw and tighten (fig 12). Be careful not to overtighten. Torque should be no more than 2 KG-CM.

After the battery is installed properly; the unit must be reset.

Reset: short circuit the two contacts shown in figure 18 while touching switch "A". This can be done with the blade of a small screw driver while held in one hand. Once these contacts have been shorted while touching switch "A", the display should appear as in figure 19.

If the display does not appear as in figure 19, repeat the process described above.

Once the unit is reset: the battery power indicator will show "FULL". There are 900 power units when a new battery is installed (100 units in each black square of the battery power indicator) Power consumption: Power is consumed by one unit each day, additionally one power unit is consumed on each dive.

(example: in a diving day consisting of 2 dives - 3 power units will be consumed)

Considering the above information, prior to "resetting" the gauge, always install a new battery in known good condition. If a used battery is installed and the circuit board "reset" the computer power information will be invalid. The computer assumes that full new battery is installed regardless of actual battery life and will state a full 900 power units remaining. continued on page 2 (figures/illustration on p. 3-7)

Lubricate the gasket seal (fig 2, item 1). Do not use too much silicone grease, a light coating is sufficient. Check the gasket groove on the housing (fig 13) and the back cover (fig 3) for scratches or small particles. Be sure these areas are clean and smooth. Place gasket in the groove in the unit housing (check position, be sure the gasket is installed in the proper manner, this gasket is not symmetrical and must fit snugly in the groove)

Replace the back cover so that it fits the shape of the gasket (fig 14)

NOTE: Be careful not to move the gasket when placing the back cover on the unit. There are two locating pins on the right and left side of the housing. Be sure these are aligned in the appropriate holes of the back cover.

Hold back cover in place with one finger and install the 5 screws in the appropriate holes, start the screws but do not tighten completely at this time. Tighten screws loosely (approximately 1.5 KG-CM) just enough to hold the back cover in place.

Tighten screws in order per figure 15, torque should be 3 KG-CM.

After battery replacement: date and time must be reset (see instructional manual for this process)

WAIT 10 MINUTES !

Testing PICO in chamber. ***It is very important to wait 10 minutes after battery change is complete before chamber testing the unit.*** This 10 minutes allows the PICO to sense ambient pressure and establish the altitude level. If you use or test it in the water before the 10 minutes is up, it starts measuring the depth with a wrong offset value and it will result in corrupt data being given.

NOTE: always chamber test the PICO in water. ***Remember to wait 10 minutes*** before doing so.

SEE PAGES 3-6 FOR FIGURES / ILLUSTRATIONS

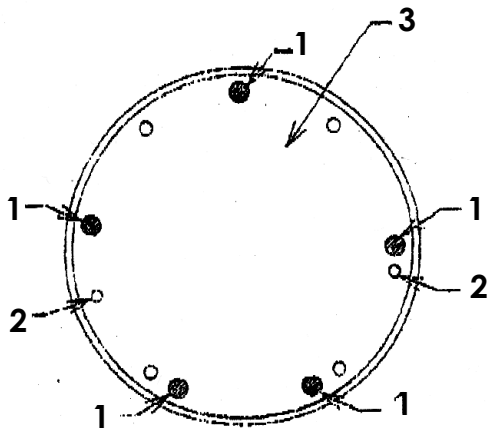

Figure 1

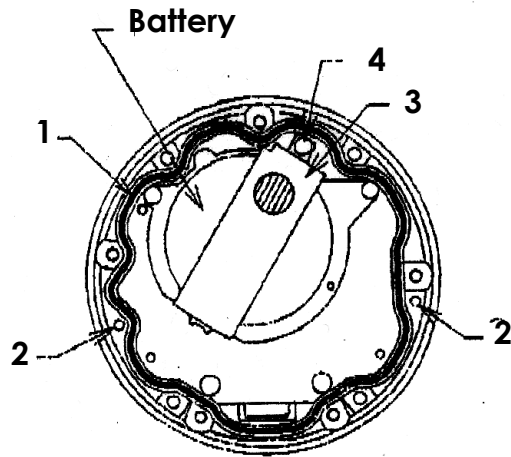

Figure 2

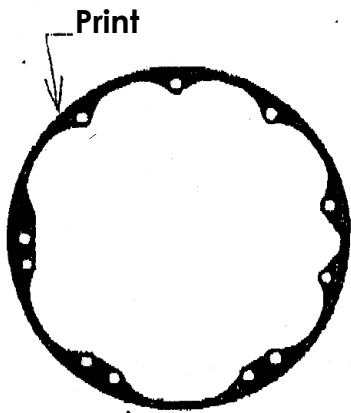

Figure 3

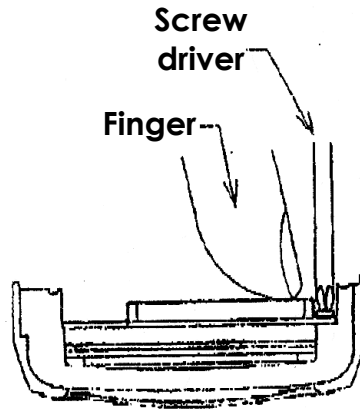

Figure 4

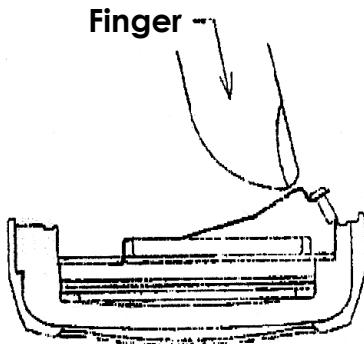

Figure 5

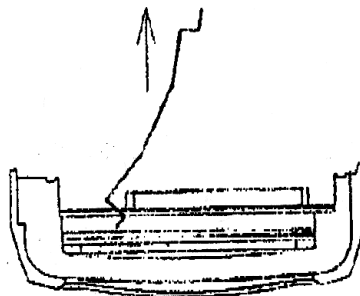

Figure 6

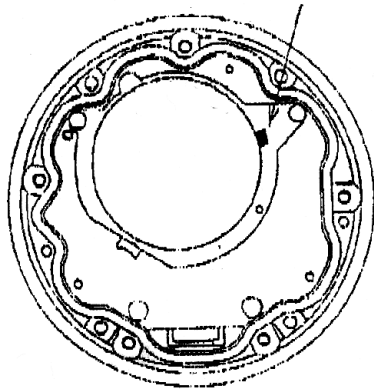

Figure 7

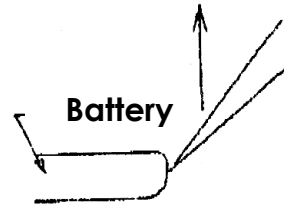

Figure 8

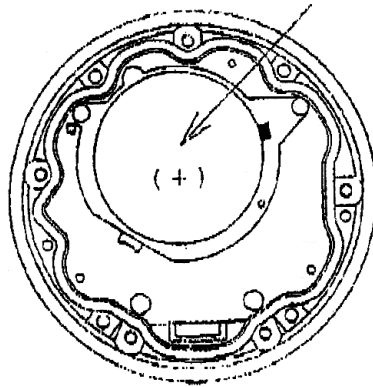

Figure 9

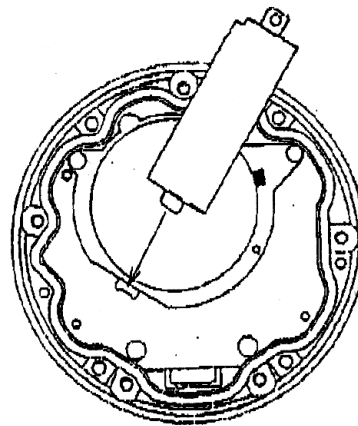

Figure 10

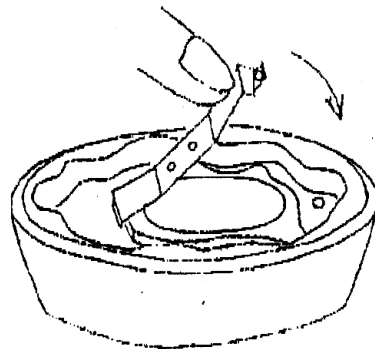

Figure 11

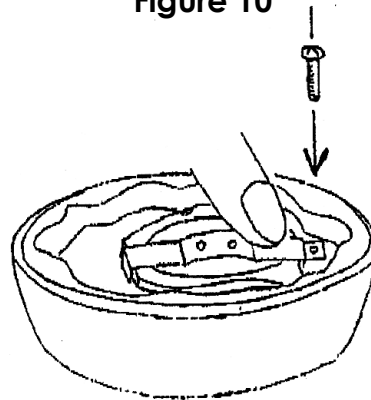

Figure 12

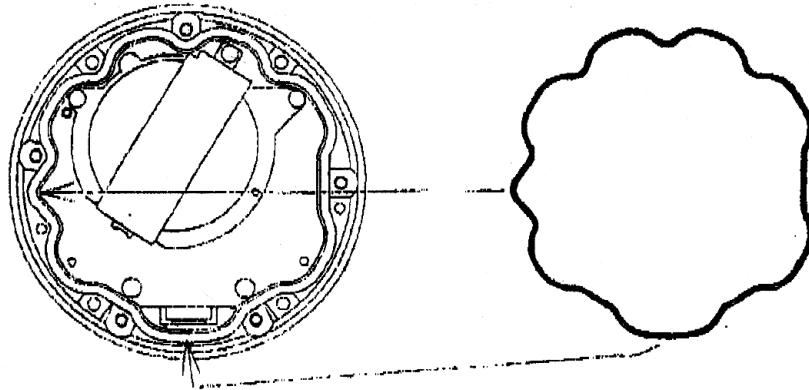

Figure 13

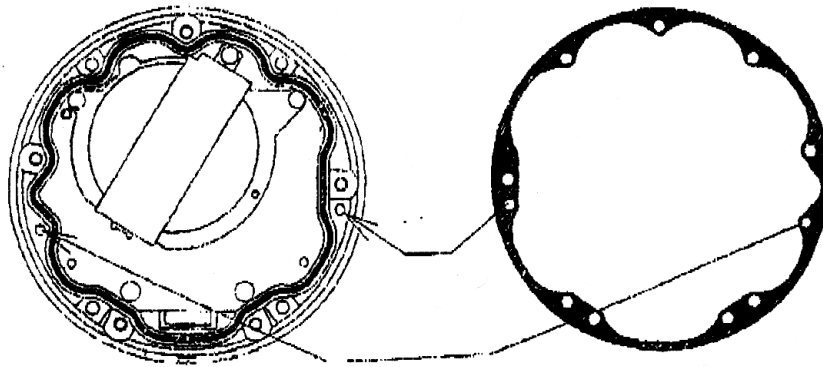

Figure 14

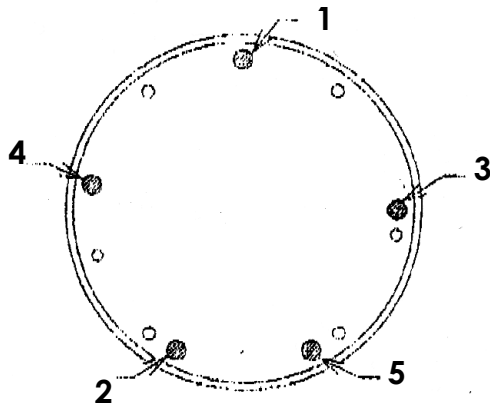

Figure 15

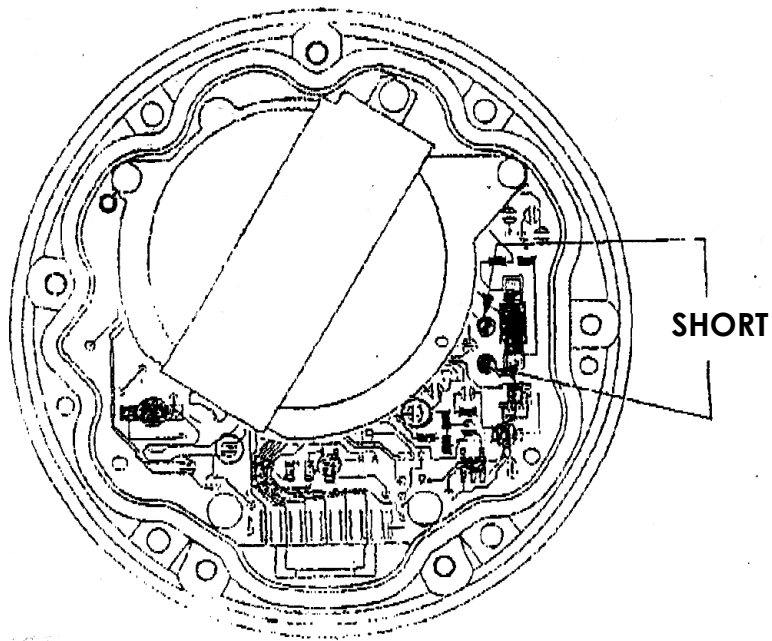

Figure 18

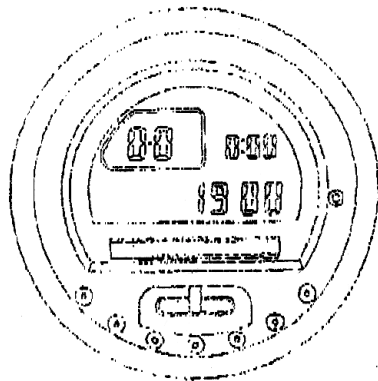

Figure 19